

DENON

STEREO CASSETTE TAPE DECK

DN-790R

OPERATING INSTRUCTIONS



IMPORTANT TO SAFETY

WARNING:

TO PREVENT FIRE OR SHOCK HAZARD, DO NOT EXPOSE THIS APPLIANCE TO RAIN OR MOISTURE.

CAUTION:

- 1. Handle the power supply cord carefully**
Do not damage or deform the power supply cord. If it is damaged or deformed, it may cause electric shock or malfunction when used. When removing it from wall outlet, be sure to remove by holding the plug attachment and not by pulling the cord.
- 2. Do not open the top cover** In order to prevent electric shock, do not open the top cover. If problems occur, contact your DENON DEALER.
- 3. Do not place anything inside** Do not place metal objects or spill liquid inside the cassette tape deck. Electric shock or malfunction may result.

Please, record and retain the Model name and serial number of your set shown on the rating label.

Model No. DN 790R

Serial No.

FOR U.S.A. & CANADA MODEL ONLY

CAUTION

TO PREVENT ELECTRIC SHOCK DO NOT USE THIS (POLARIZED) PLUG WITH AN EXTENSION CORD, RECEPTACLE OR OTHER OUTLET UNLESS THE BLADES CAN BE FULLY INSERTED TO PREVENT BLADE EXPOSURE.



CAUTION

RISK OF ELECTRIC SHOCK

DO NOT OPEN



CAUTION: TO REDUCE THE RISK OF ELECTRIC SHOCK, DO NOT REMOVE COVER (OR BACK). NO USER SERVICEABLE PARTS INSIDE. REFER SERVICING TO QUALIFIED SERVICE PERSONNEL.



The lightning flash with arrowhead symbol within an equilateral triangle is intended to alert the user of the presence of uninsulated "dangerous voltage" within the product's enclosure that may be of sufficient magnitude to constitute a risk of electric shock to persons.



The exclamation point within an equilateral triangle is intended to alert the user of the presence of important operating and maintenance (servicing) instruction in the literature accompanying the appliance.

FRONT PANEL

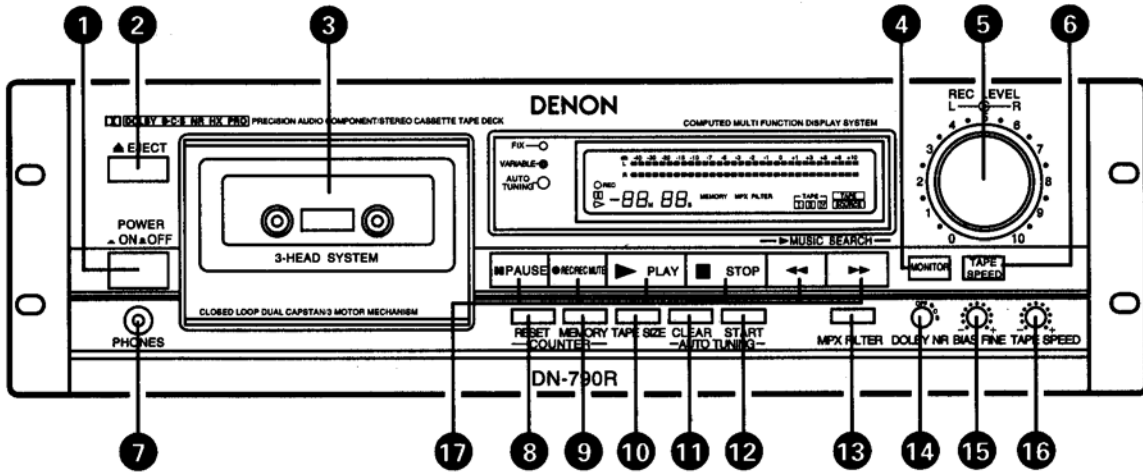

DISPLAY

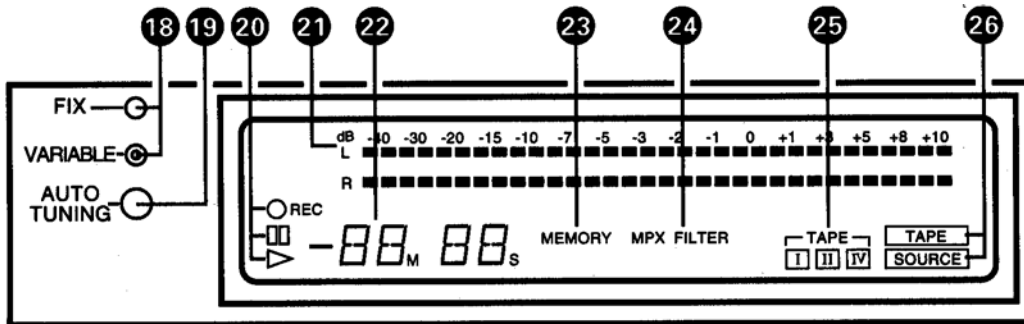

REAR PANEL

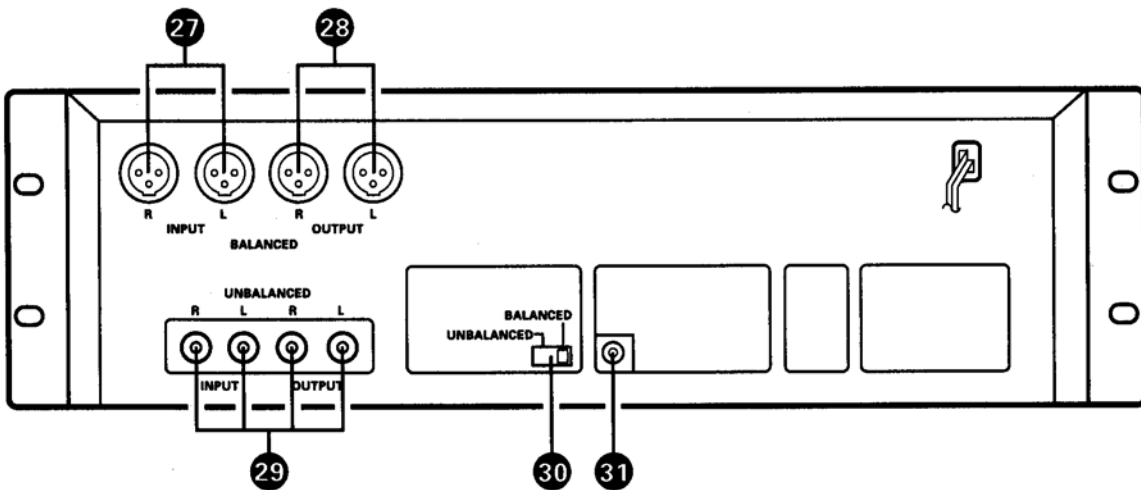

SAFETY INSTRUCTIONS

1. Read Instructions – All the safety and operating instructions should be read before the appliance is operated.
2. Retain Instructions – The safety and operating instructions should be retained for future reference.
3. Heed Warning – All warnings on the appliance and in the operating instructions should be adhered to.
4. Following Instructions – All operating and use instructions should be followed.
5. Water and Moisture – The appliance should not be used near water – for example, near a bathtub, washbowl, kitchen sink, laundry tub, in a wet basement, or near a swimming pool, and the like.
6. Carts and Stands – The appliance should be used only with a cart or stand that is recommended by the manufacturer.
- 6A. An appliance and cart combination should be moved with care. Quick stops, excessive force, and uneven surfaces may cause the appliance and cart combination to overturn.
7. Wall or Ceiling Mounting – The appliance should be mounted to a wall or ceiling only as recommended by the manufacturer.
8. Ventilation – The appliance should be situated so that its location or position does not interfere with its proper ventilation. For example, the appliance should not be situated on a bed, sofa, rug, or similar surface that may block the ventilation openings; or, placed in a built-in installation, such as a bookcase or cabinet that may impede the flow of air through the ventilation openings.
9. Heat – The appliance should be situated away from heat sources such as radiators, heat registers, stoves, or other appliances (including amplifiers) that produce heat.
10. Power Sources – The appliance should be connected to a power supply only of the type described in the operating instructions or as marked on the appliance.
11. Grounding or Polarization – Precautions should be taken so that the grounding or polarization means of an appliance is not defeated.



12. Power-Cord Protection – Power-supply cords should be routed so that they are not likely to be walked on or pinched by items placed upon or against them, paying particular attention to cords at plugs, convenience receptacles, and the point where they exit from the appliance.
14. Cleaning – The appliance should be cleaned only as recommended by the manufacturer.
15. Power Lines – An outdoor antenna should be located away from power lines.
16. Outdoor Antenna Grounding – If an outside antenna is connected to the receiver, be sure the antenna system is grounded so as to provide some protection against voltage surges and built-up static charges. Article 810 of the National Electrical Code, ANSI/NFPA 70, provides information with regard to proper grounding of the mast and supporting structure, grounding of the lead-in wire to an antenna-discharge unit, size of grounding conductors, location of antenna-discharge unit, connection to grounding electrodes, and requirements for the grounding electrode. See Figure A.
17. Nonuse Periods – The power cord of the appliance should be unplugged from the outlet when left unused for a long period of time.
18. Object and Liquid Entry – Care should be taken so that objects do not fall and liquids are not spilled into the enclosure through openings.
19. Damage Requiring Service – The appliance should be serviced by qualified service personnel when:
 - A. The power-supply cord or the plug has been damaged; or
 - B. Objects have fallen, or liquid has been spilled into the appliance; or
 - C. The appliance has been exposed to rain; or
 - D. The appliance does not appear to operate normally or exhibits a marked change in performance; or
 - E. The appliance has been dropped, or the enclosure damaged.
20. Servicing – The user should not attempt to service the appliance beyond that described in the operating instructions. All other servicing should be referred to qualified service personnel.

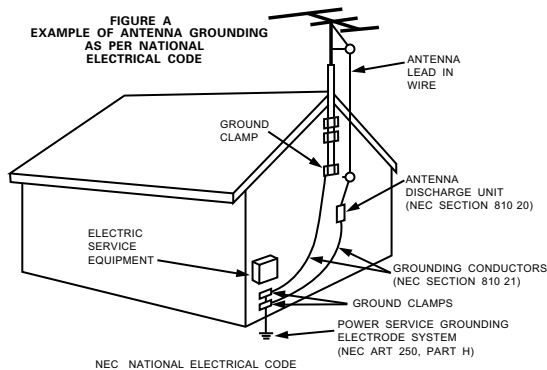

NOTE ON USE



Avoid high temperatures
Allow for sufficient heat dispersion
when installed on a rack.

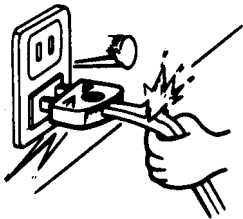

Handle the power cord carefully. Hold
the plug when unplugging the cord.



Keep the set free from moisture,
water, and dust.

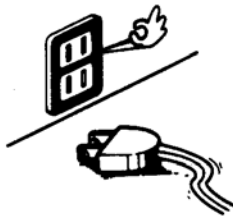

Unplug the power cord when not
using the set for long periods of time.



"(For sets with ventilation holes)
Do not obstruct the ventilation holes.



Do not let foreign objects in the set.



Do not let insecticides, benzene, and
thinner come in contact with the set.



Never disassemble or modify the set
in any way.

Thank you very much for purchasing the DENON component stereo cassette tape deck.

DENON proudly presents this advanced tape deck to audiophiles and music lovers as a further proof of DENON's non compromising pursuit of the ultimate in sound quality. The high quality performance and easy operation are certain to provide you with many hours of outstanding listening pleasure.

- TABLE OF CONTENTS -

FEATURES6
 CONNECTION7
 NAMES AND FUNCTION OF PARTS.....8, 9
 CASSETTE TAPES9
 AUTO TAPE SELECT FEATURE10
 PLAYBACK10
 RECORDING10
 AUTOTUNING11
 MONITOR BUTTON11
 PROPER RECORDING LEVEL12
 RECORDING BIAS ADJUSTMENT12
 REC/REC MUTE BUTTON12
 MUSIC SEARCH SYSTEM12
 TAPE COUNTER AND MEMORY STOP13
 DOLBY NOISE REDUCTION SYSTEM13
 DOLBY HX-PRO HEADROOM EXTENSION SYSTEM ...13
 WIRED REMOTE CONTROL BOX CIRCUIT DIAGRAM 14
 MAINTENANCE15
 TROUBLESHOOTING16
 SPECIFICATIONS16

Please check to make sure the following items are included with the main unit in the carton:

- (1) Operating Instructions..... 1
- (2) Connection Cords2

FEATURES _____

- Computer Controlled Mechanism
- Closed-loop Dual-capstan Tape Transport
- Non-slip Reel Drive for Stabilizing Tape Tension
- Dual Power Supply
- 3-Head Design Utilizes The Amorphous Head
- Dolby S Noise Reduction System
- Dolby HX PRO System
- Dolby B & C Noise Reduction System
- XLR Type (Balanced) Input/Output Connectors Provided
- Auto Tuning
- Manual Bias Adjustment Controls
- Computing Linear or Real Time Tape Counter With 4-Digit Read out and Memory Stop
- Auto Tape Selector.
- 19-inch Rack Mountable
- Speed Control of Approximately $\pm 12\%$
- Accurate Music Search System

CONNECTION

- Leave your entire system (including this cassette deck) turned off until all connections between the deck and other components have been completed.

• Connecting the Deck to an Amplifier

Before connecting the deck to your amplifier, it is a good practice to review your amplifier's instruction manual.

Use the white plugs for the left channel and red plugs for the right channel.

• Tape Dubbing

Many stereo amplifiers and receivers have tape dubbing circuitry so that tape duplication can be performed between two or more tape decks. Review your amplifier's instruction manual for a full explanation of this mode of operation.

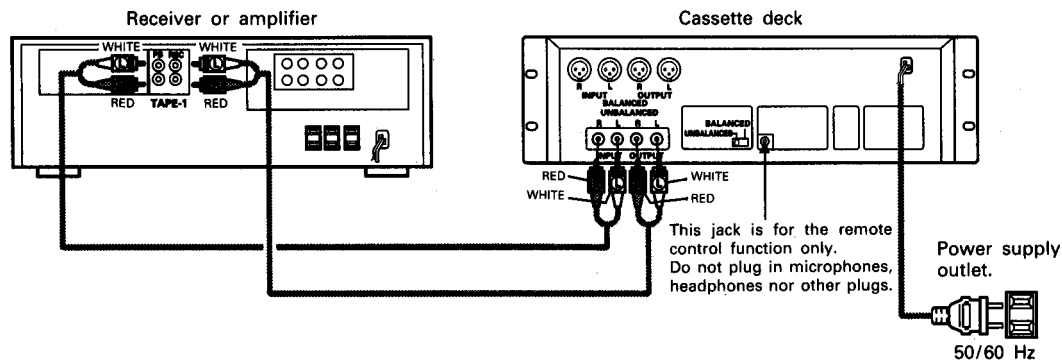

• Systems Remote Control (Refer to page 14)

A wired remote control box can be connected to this unit. No remote control box is included. For remote control, the user should build a remote control box referring to the schematic diagram (remote control box schematic diagram). Connect the remote control terminal to the remote control jack on the rear panel.

• Connecting Headphones

To listen through headphones, plug your headphones into the PHONES jack.

• Installation Precautions

If the deck is placed near an amplifier, tuner or other components, noise (induced hum) or beat interference may result (especially during AM or FM reception). If this occurs, separate the deck from other components or reorient its position.

NOTE:

Use this unit in a horizontal orientation.

When the unit is used with the front panel facing upward (and the unit is in a vertical orientation) or when the front panel is on an incline, the unit will not operate properly.

NAMES AND FUNCTIONS OF PARTS (Refer to Page3.)

FRONT PANEL

- 1 Power Switch (POWER)**
Controls the supply of AC power to the deck. One push turns the deck on, a second push turns it off. The deck remains in a stand by (non operative) mode for approximately 2 seconds after it is switched on.
- 2 EJECT button**
Press this button to eject the cassette. When the deck is operating (tape is running), press the stop button first to stop the tape transport; then press the EJECT button.
- 3 Cassette compartment cover**
If this compartment cover is not closed completely, the deck's transport controls will remain inoperative.
- 4 MONITOR button**
The SOURCE position of this button allows you to monitor the source program before it is recorded. The TAPE position of this button is used for tape playback monitoring or simultaneous monitoring during recording.
- 5 REC LEVEL control**
The recording input level is adjusted by this knob. The levels in the left and right channels can be changed independently.
- 6 TAPE SPEED button**
This button is for setting the tape speed to the fixed speed (FIX) or variable speed (VARIABLE) position.
When set at the FIX position, the tape is played at the standard (fixed) speed regardless of the position of the tape speed control knob.
When set at the VARIABLE position, the tape speed changes according to the position of the tape speed control knob.
- 7 PHONES jack**
For private music enjoyment without disturbing others, or for monitoring a recording, a set of headphones may be plugged in. Impedance should be from 8 to 1200 ohms.
- 8 COUNTER RESET button**
(for the real time counter and the linear counter too) Operation of the button resets the counter to all zero.
- 9 MEMORY STOP button**
During rewinding operations, the tape will stop at the "00 00" counter point automatically when this button is pressed in.
- 10 TAPE SIZE button**
You can know accurate elapsed time of the tape by adjusting the TAPE SIZE button to the tape size used. When the TAPE SIZE button is pressed, the current tape size is displayed for 1 sec in the 4 figures counter. If you further press the button during the display, the tape size will change in the following cycle.
C 90 → C 74 → C 60 → C 100 → C 90 ...etc
- 11 Auto Tuning, CLEAR button (CLEAR)**
When this button is pressed after setting auto tuning or during the auto tuning operation, auto tuning is cleared and the recording characteristics are reset to the standard values. Refer to page 11.
- 12 Auto Tuning START button (START)**
When this button is pressed, the auto tuning operation starts and the recording characteristics most suited for the tape being used are set automatically. Refer to page 11.
- 13 MPX FILTER button**
The MPX FILTER button should be used to prevent interference with the Dolby NR circuit when making Dolby NR encoded recordings of FM stereo programs. When making Dolby NR encoded recordings from any program source other than FM stereo, leave this button in the "OFF" position.
- 14 DOLBY NR switch**
There are independent buttons for the Dolby NR "OFF", "B", "C" and "S" positions. When recording tapes, set the Dolby NR function as desired.
When playing tapes, set the Dolby NR function to the same position as when the tape was recorded.
- 15 BIAS FINE control**
(for NORMAL, Cr02 and METAL tape)
Adjust the bias according to the tape characteristics. Standard biasing is obtained at the center click stop position.
- 16 TAPE SPEED control**
Use this knob to vary the tape speed.
First set the tape speed button to the VARIABLE position.
The speed can be varied within a range of approximately ±12% according to the position of the tape speed control knob.

17. Tape transport controls

▶ PLAY	PLAY button	Press to playback tape.
■ STOP	STOP button	Press to stop tape in any mode.
◀◀	REW button	Press for fast rewind.
▶▶	FF button	Press fast forward tape winding.
● REC/REC MUTE	RECORD/MUTE button	To begin recording, press the RECORD and PLAY button simultaneously. If only the RECORD button is pressed, the deck is placed in the REC PAUSE (record standby) mode. When this button is pressed under the REC PAUSE state, the mode shifts to the Auto Rec Mute. when this button is pressed for making a non-recorded part between two melodies, about 5 sec of non-recorded part can automatically be created.
PAUSE	PAUSE button	Press this button to enter the recording pause mode from the recording or recording mute mode. Press this button to enter the playback pause mode from playback mode.

DISPLAY

- 18 TAPE SPEED indicator**
"FIX" or "VARIABLE" is interlocked with the TAPE SPEED button. The tape speed can be controlled when "VARIABLE" is light.
- 19 AUTO TUNING indicator**
This indicator flashes during the auto tuning operation and stops flashing, remaining lit, once auto tuning is completed. The indicator turns off when the CLEAR button is pressed, and when the auto tuning data is cleared.
- 20 PLAY, PAUSE and REC indicator**
When the PLAY, PAUSE and REC buttons are pressed, this indicator will light.
- 21 Fluorescent peak meters**
These meters indicate recording or playback peak levels for each channel. For peak levels exceeding 7 dB, the Auto Peak Hold Feature holds the peak level reading for approximately 1 seconds.
- 22 Tape counter**
Tape passage is indicated digitally in minutes and seconds. When "M" and "S" are lit, the counter is set to the real time display mode. When "M" and "S" are off, the counter is set to the linear display mode. For an explanation of the real time and linear time display modes, refer to the section "TAPE COUNTER AND MEMORY STOP".
- 23 MEMORY indicator**
This indicator light is interlocked with the memory stop button. (MEMORY)
- 24 MPX FILTER indicator**
This indicator light is interlocked with the MPX FILTER button.
- 25 TAPE SELECT indicator**
This indicator light is interlocked with the Auto Tape Select feature which automatically adjusts the deck to the type of tape in use. (TYPE I TYPE II or TYPE IV).
- 26 MONITOR indicator**
This indicator light is interlocked with the MONITOR button to inform the use of the selected monitoring source TAPE or SOURCE.

REAR PANEL

- 27 XLR Type input connectors (BALANCED INPUT)**
- These are active balanced inputs using XLR type connectors (XLR 3 31). Connected them to the balanced output terminals on an amplifier or console.
 - Pin layout:
Pin 1 Common
Pin 2 Cold
Pin 3 Hot
 - Applicable connector: XLR 3 12C or the equivalent.
- NOTE:** Do not short circuit the hot or cold pin with the common pin.
- 28 XLR Type output connectors (BALANCED OUTPUT)**
- These are active balanced outputs using XLR type connectors (XLR 3 32). Connected them to the balanced input terminals on an amplifier or console.
 - Pin layout:
Pin 1 Common
Pin 2 Cold
Pin 3 Hot
 - Applicable connector: XLR 3 11C or the equivalent.
- NOTE:** Do not short circuit the hot or cold pin with the common pin.
- 29 RCA Pin Jack (UNBALANCED)**
- 30 INPUT Selector switch**
Use this to select the input jack to be used.
- 31 Remote Control Jack**
Use this to operate the DN 790R using the remote control box. (The remote control box is not included with the DN 790R.)

CASSETTE TAPES

- Handling Precautions**
- C 120 Cassettes:
C 120 cassette tapes are not recommended as they use a very thin tape base which may become tangled around the capstan or pinchroller.
- Tape Slack:
This cassette deck incorporates an automatic tape slackness preventive mechanism, but it can not prevent such a slackness as shown below. Remove it with a pencil or the like prior to use.

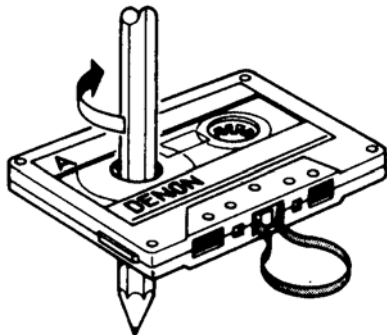

- Storage Precautions**
- Do not store cassette tapes in a place where they will be subject to:
 - Extremely high temperature or excessive moisture
 - Excessive dust
 - Direct sunlight
 - Magnetic fields (near TV sets or speakers)
- To eliminate tape slack, store your cassettes in cassette cases with hub stops
- Accidental Erasure Prevention**
- Every cassette has erasure prevention tabs for each side. To protect your valuable recorded tapes from accidental or inadvertent erasure, remove the tab for the appropriate side with a screwdriver or other tools.
- To record on a tape with the erasure prevention tabs removed, cover the tab holes with plastic tape.



Erasure prevention tab for side B

AUTO TAPE SELECT FEATURE

This Stereo Cassette Deck contains an Auto Tape Select feature which automatically selects the optimum bias and equalization for the tape in use. This is accomplished by detection of tape type detection holes in the cassette housing.

- If a tape without tape type detection holes is used, the deck will automatically adjust itself for normal tapes.

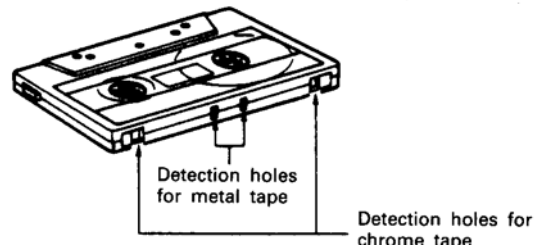

PLAYBACK

- Switch on your amplifier or receiver.
- Set the TAPE MONITOR switch on your amplifier or receiver to the TAPE position.
- Operate the deck in numerical order as illustrated below:

- ① PHONES
Playback sound is fed into the headphones set.
- ② POWER
Push the switch to turn "ON" the power.
- ③ EJECT
Press the EJECT button to open the cassette compartment.
Cassette Compartment Cover
Load the cassette tape.
- ⑤ DOLBY NR
For recordings made without Dolby NR, set to "OFF".
For recordings made with Dolby B NR, set to "B".
For recordings made with Dolby C NR, set to "C".
For recordings made with Dolby S NR, set to "S".

- ⑥ ▶ PLAY
Push the PLAY button (The PLAY indicator will light up).
 - When playback is finished, press the stop button.
 - To restart the tape, press the PLAY button.
 - If different types of Dolby Noise Reduction are used for record and playback, playback response will be adversely effected.

RECORDING

- Switch on the source component (tuner, amplifier, etc.).
- Set the TAPE MONITOR switch on your amplifier or receiver to the SOURCE position.

- ① POWER
Push the switch to turn "ON" the power.
- ② EJECT
Press the EJECT button to open the cassette compartment.
Cassette Compartment Cover
(Make sure the erasure prevention tab has not been removed from the cassette shell half.)
- ④ DOLBY NR
Set, in accordance with the recording to be made. For recordings without Dolby NR, set to "OFF". For recordings with Dolby B NR, set to "B". For recordings with Dolby C NR, set to "C". For recordings with Dolby S NR, set to "S". Future mistakes during playback can be avoided if the cassette is so marked for Dolby NR encoded recordings.
- ⑤ MPX FILTER
Button **13** it "ON" for the DOLBY NR recording of FM broadcasts (The MPX FILTER indicator **24** will light up).

- ⑥ • REC/REC MUTE
When pressed, the deck goes into the record standby mode. The O REC and OV PAUSE indicators ⑧ will light. Initial setting of recording levels should be made in the record standby mode. The tape speed control is set to the fixed mode and "FIX" lights on the display.
- ⑦ REC LEVEL
Used to set the recording level.
The left and right channels can be adjusted independently. Normally set the grooves in the controls for the left and right channels to the same positions. To change the left/right recording balance, operate the controls for the left and right channels separately.
- ⑧ (PLAY)
When pressed, the recording will start.
(The >PLAY and OREC indicators ⑧ will light up).

Note:

In the recording mode, the variable speed mode cannot be selected, and the mode is automatically switched to the fixed speed mode.

- When recording is finished, press the STOP button.

Caution:

Be careful not to erase important recordings by mistake. Mis erasing can be avoided by following the two steps below:

1. If the PLAY button (**17**) is pressed while the REC indicator is on, the tape will be recorded.
2. If the PLAY and RECORD (*REC) button (**17**) are pressed at the same time, the tape will be recorded.
3. Performing the record pause or the stop operation during recording will create a discontinuous portion in the recording signal. The previously recorded signal may remain after erasure at this connecting portion. Also, a very small amount of the end portion of the previous song may be erased.

AUTO TUNING

Though tapes may be of the same type, tapes of different manufacturers and even tapes of the same manufacturer may have slightly different recording characteristics. The auto tuning system is a function which automatically sets the optimum recording characteristics to take maximum advantage of the performance of individual tapes.

- ① Set the cassette tape to be tuned into the cassette box.
- ② Set the Dolby NR switch for the position to be used for recording.
- ③ Press the \square REC/REC MUTE button to set the recording pause mode. (The "O" Rec and "II" PAUSE indicators will light up.)
- ④ Press the START button. Tuning starts. The AUTO TUNING indicator flashes during tuning.
- ⑤ After 5 to 10 seconds, tuning is completed, the tape is automatically rewind to a position a little before the position at which tuning started, and the AUTO TUNING indicator stops flashing, remaining lit.
- ⑥ To cancel the setting:
 - During tuning: Press the STOP or CLEAR button.
 - After tuning: Press the CLEAR button.
 - Turn off the power.



The recording characteristics are reset to the standard values.

Note: To achieve the optimum recording characteristics, we recommend always tuning each tape before recording, even for tapes of the same type and the same manufacturer.

Caution:

1. If auto tuning is performed with recorded tapes, the recorded sound will be erased. To avoid erasing the recorded sound, perform auto tuning using a blank section of at least 30 seconds.
2. If tuning is started from the beginning of the tape (the leader tape section), tuning is performed after the tape is forwarded to the magnetic portion. In this case, the tape is rewound to a position a little before the beginning of the magnetic portion (at the leader tape section) after tuning is completed.
3. If the tape is too near the end, the tuning mode may be canceled before tuning is completed.
4. The bias control knob on the front panel functions during auto tuning, so we recommend setting it to the center click position. If the bias control knob is set too far in one direction, the auto tuning system may not be able to fully correct the change in the frequency response and level, resulting in poor recording characteristics.

MONITOR BUTTON

This Stereo cassette deck uses a three head system which permits simultaneous "off the tape monitoring" during recording.

Recording		The signal recorded on the tape is monitored simultaneously "off-the-tape". This monitoring mode enables you easy check for optimum recording levels. In the TAPE mode, the FL PEAK METER indicates the signal levels played back off-the-tape.
		The SOURCE position enables you to monitor the input source signal before it is recorded on the tape. Using the FL PEAK METER, this mode is convenient for setting recording levels or input level monitoring during recording.
Playback		During playback, the MONITOR button must be placed in the TAPE position. If it is set in the SOURCE position, the signal from the tape won't be heard.

PROPER RECORDING LEVEL

A too high recording level can saturate the tape and cause distortion. On the other hand, if the recording levels are set too low, soft passages will be marked by residual noise. Proper recording level is the single most important factor for making well balanced recordings.

Guideline for maximum recording level

Normal tape	TYPE I	+1 dB levels on peaks
CrO2 tape	TYPE II	+3 dB levels on peaks
Metal tape	TYPE IV	+5 dB levels on peaks

Note:

Optimum recording levels can differ depending on program sources or the type of tape used.

RECORDING BIAS ADJUSTMENT

- Use this to change the characteristics to suit your tastes, taking advantage of the performance of the tape.
- For normal recording, set the control at the center click position to achieve satisfactory characteristics.
- If the bias is low (when the knob is turned to the " - " side), the high frequencies increase, but so does distortion. If the bias is high, (when the knob is turned to the " + " side), the high frequencies decrease, but so does distortion.



Caution:

The bias control knob functions independently of the auto tuning system, so if it is adjusted after auto tuning, the bias changes starting from a flat recording characteristic.

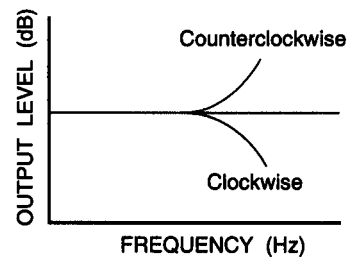

REC/REC MUTE BUTTON

REC/REC MUTE is the DENON's unique and convenient function. By using this button, it is easily possible to insert a suitable space (the non recorded part) between two melodies.

1. When you want to make about 5 seconds of non recorded part after the recording state:
Press the REC/REC MUTE button. The recorder will automatically create about 5 seconds of non recorded part and will stay in the recording standby state.
2. To create about 5 seconds of non recorded part after the standby state: Press the REC/REC MUTE button, and the recorder will enter the non recording state, automatically create about 5 seconds of non recorded part and stay in the standby state.

3. To cancel the non recording state (the REC MUTE state): Press the PAUSE button, and the recorder will cancel the non recording state and will stay in the standby state.
4. To extend the non recording state (the REC MUTE state) for further 5 seconds or more: Press the REC/REC MUTE button, and the non recorded part will automatically be extended for another 5 seconds.

MUSIC SEARCH SYSTEM

This device is a convenient system which detects the non recorded part of more than 4 seconds between melodies, cues the next melody while the present melody is being reproduced or automatically detects the beginning of the melody now being reproduced and makes it into the reproduceable state.

1. For cueing the next melody while the present melody is being reproduced:
At PLAY mode, depress the PLAY button and the FF button simultaneously. This device will detect the interval between melodies with the CUE state on, automatically become the PLAY mode and begin performing the next melody.
2. For hearing again the melody being reproduced:
At PLAY mode, depress the PLAY button and the REW button simultaneously. This device will detect the interval between melodies with the REVIEW state on, automatically become the PLAY mode, detect the beginning of the melody now being performed and play it from the first again.

NOTE: Note about MUSIC SEARCH action:

MUSIC SEARCH is a function which operates by detecting a comparatively long non recorded part on the tape. Therefore, MUSIC SEARCH may not operate normally in the following cases.

- Sound on the tape is interrupted by speech or conversation.
 - Long periods of pianissimo (Softly played music) or non recorded intervals occur on the tape.
 - The tape has picked up noise in a non recorded interval.
 - Non recorded intervals on the tape are less than 4 seconds in length.
 - Noise emitting electrical appliances are in operation nearby, i.e.;
- Electric razors, drills, refrigerators, etc.

TAPE COUNTER AND MEMORY STOP

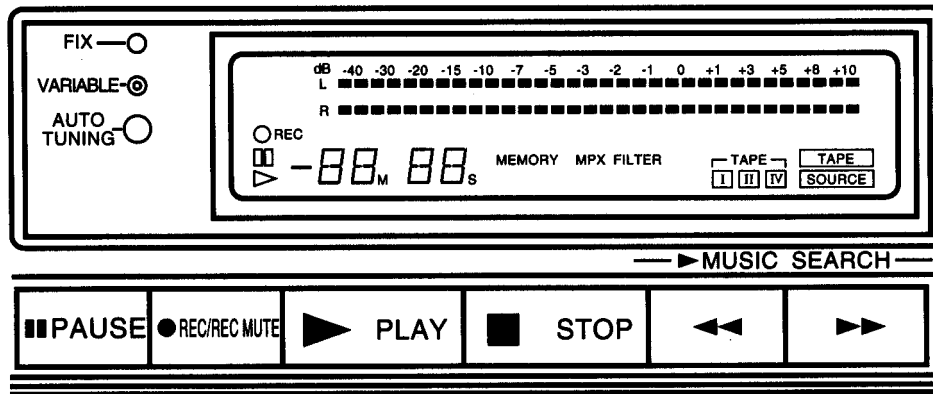

1) Operation of the Real Time Tape Counter and the Linear Tape Counter

- Real Time Tape Counter
The time of the tape traveling at a constant speed is indicated in "M" (minutes) and "S" (seconds).
A microcomputer measures and displays the time with high precision.
Display example: 32: 10: 32 minutes, 10 seconds.
 - Linear Tape Counter
The tape travel time is indicated with a 4 digit value. The first two digits indicate the minutes, the last two digits the seconds.
Display example: 3456 34 minutes, 56 seconds.
- (1) Press the RESET button to reset the counter to: 00: 00:
"M" and "S" are not displayed when "VARIABLE" is displayed. They are also not displayed when "FIX" is displayed during the fast forward, rewind, music search operations or when the STOP button has been pressed during an operation.
 - (2) Select "FIX" using the TAPE SPEED button. "FIX" appears on the display, the counter is set to the real time mode, and "M" (minutes) and "S" (seconds) appear.
 - ① The counter remains in the real time mode when the play, record play, pause, record pause or stop mode is selected at this time.
 - (3) The counter automatically switches to the linear mode if the fast forward or rewind mode is set from any of the modes in (2) ① or if the "VARIABLE" mode is set during playback.
 - (4) If the music search mode is selected, the counter automatically switches to the linear mode, then switches back to the real time mode once playback begins after the music search operation.

• Note

The method of measuring the time and the precision differ for the real time tape counter (fixed speed travel) and the linear tape counter. The tape may not be returned to the precise position when the fast forward, rewind, music search or memory rewind operations are used, but this is not a malfunction.

Use the real time tape counter to measure the accumulated time at constant speed without counting the time in which the pause, stop and record pause modes are set.

- (5) The counter is reset to "00 00" when the EJECT button is pressed.

2) Operation of MEMORY STOP

- (1) During recording or playback operations, MEMORY STOP can be used to locate a particular point on the tape. At the desired point, reset the counter to "00.00".
With the MEMORY STOP button in the "ON" position, the deck will stop at the "00 00" point (actually "00 02" and "00 00") during REWIND operations.
- (2) The MEMORY indication will light when this function is activated.

(3) Notes:

When the power is turned "OFF", this function is automatically deactivated.

The MEMORY STOP is accurate to 5 on the counter, and will stop between "00 02" and "00 00".

The MEMORY STOP is released by pressing the EJECT button.

3) Display Back up

- (1) The DOLBY NR, MPX FILTER, COUNTER VALUE, TAPE SPEED and TAPE SIZE functions are protected for approximately one month by a memory back up.
Once the back up period is up, the DOLBY NR and MPX FILTER settings are set to off, the TAPE SIZE setting is reset to "C 90", the Tape Speed setting is set to FIX, and the counter is reset to "00 00"

DOLBY NOISE REDUCTION SYSTEM

- The Dolby noise reduction system substantially reduces the tape background noise (hiss) inherent in the cassette medium.
- Tape background noise consists primarily of high frequency information, which is particularly annoying during soft passages. The Dolby NR system increases the level of low volume mid and high frequency signal during recording and reduces the level of these signals by an identical amount during playback. As a result, the playback signal is identical to the original source signal, but the level of background noise generated by the tape is greatly reduced.

- The operating principle of Dolby C NR is similar to that of Dolby B NR except for the encoding /decoding response curves. The noise reduction effect obtained with Dolby C NR is up to 20 dB, compared to 10 dB with Dolby B NR. In addition, Dolby C NR uses an anti saturation network and spectral skewing circuitry for a significant improvement in the dynamic range of the mid to high frequencies.
- The S type provides a maximum noise reduction effect of 24 dB in the high frequencies and 10 dB in the low frequencies, and expands the dynamic range over a wide frequency range.

DOLBY HX-PRO HEADROOM EXTENSION SYSTEM

This deck is equipped with the Dolby HX PRO headroom extension system. Since the system functions automatically during recording, no switching operation or adjustment is required. The system is effective with any type of Normal, Cr02 and Metal tape.

The Dolby HX PRO headroom extension system functions during recording to lift up the saturation level in the treble range. Therefore, most of the treble range components distorted or lost during recording on conventional cassette decks are more faithfully recorded on the new cassette deck.

Features of the Dolby HX PRO Headroom Extension System

- (1) Performance of Normal and Cr02 tapes can be upgraded closer to that of Metal tapes.
- (2) The dynamic range in the treble is improved significantly.
- (3) Since no decoding in playback is necessary, the improvement can be obviously heard on any hi fi playback system including portable components and car systems.
- (4) The system functions whether the Dolby B/C/S NR is engaged or not.

WARNING:

INSTRUCTIONS ON THIS PAGE ARE FOR QUALIFIED SOUND INSTALLERS AND SERVICE PERSONNELS ONLY.

WIRED REMOTE CONTROL BOX CIRCUIT DIAGRAM

1. Circuit Diagram

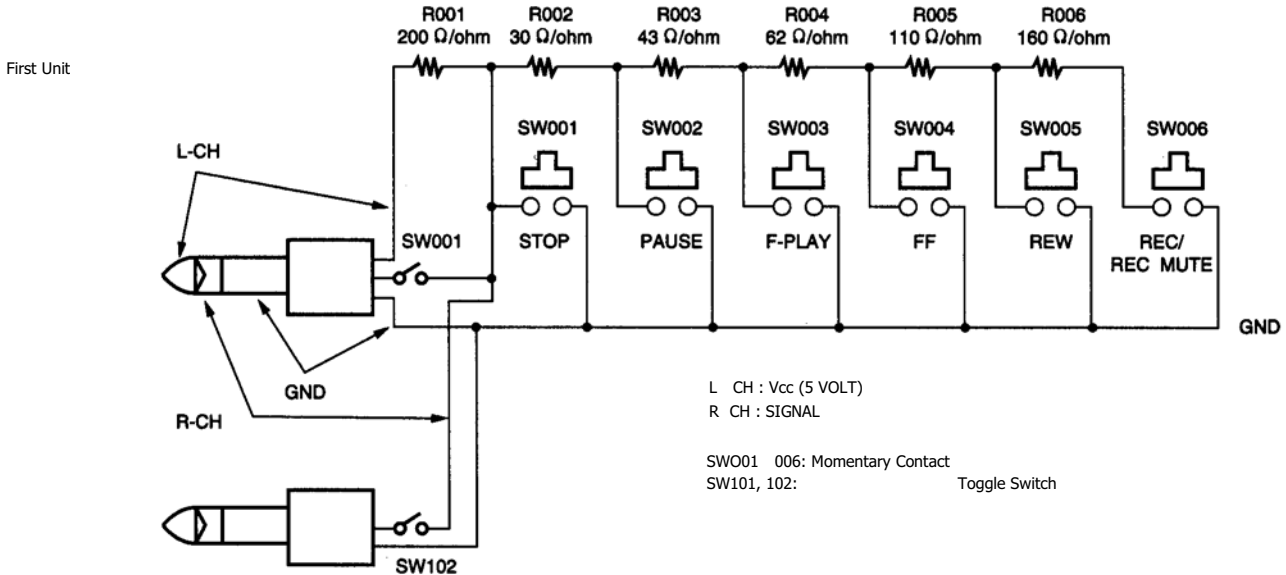

Second and Subsequent Units

- Make a control box using the supplied remote control box connection wire.
- Do not connect the left channel of the plug (Vcc) with 8001 (200 ohms) in the second and subsequent units.
- Use resistors having a tolerance of within ±5% (1/4W). Use of resistors having a poorer tolerance will cause incorrect operation.
- Never short circuit the left channel line (Vcc). Doing so will damage the main unit.

2. Operation with Parallel Connections

A number of DN 790R units can be simultaneously operated in parallel with 1 button. Operation with parallel connections can be used with a maximum of 5 units. Connection of 6 or more units will lead to incorrect operation.

3. Cable Length

The longer the length of the cable, the more susceptible the system will be to the effects of external noise. Keep cable lengths to 2 m or less. Do not locate equipment that produces electrical noise in the vicinity of the cable. Doing so might lead to incorrect operation due to the noise.

4. Do not disconnect or connect the remote control plug during operation of the unit.
The pins of the plug might cause a short circuit of the pins inside the jack which can stop the operation.
5. Pressing more than one button of the wired remote control box at the same time (for combined operations) is not possible.
A music search operation will not result from pressing the PLAY and FF, or PLAY and REW buttons at the same time.
6. Pressing a button of the wired remote control box and a button of the main unit, DN 790R, (for combined operations) is not possible.
7. Do not switch the power on or off when the cable of the wired remote control is connected. Doing so will cause incorrect operation.

MAINTENANCE

- **Removing the cassette compartment cover**

It will be more convenient if the cassette compartment cover is removed during the cleaning of the pinchroller and heads, or during demagnetizing of heads.

Follow these procedures:

1. Press the EJECT button to open the cassette compartment.
2. Hold only the cover of the cassette compartment and pull it up. The compartment cover is removed from the front.

When attaching the cassette compartment cover, reverse the above procedure.

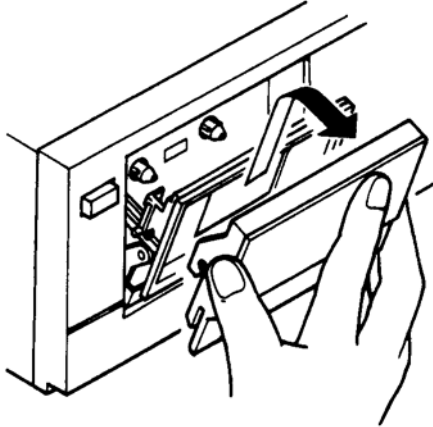

- **Head Cleaning**

After long usage, tape coating or dust may adhere to the heads, causing deterioration of sound. Clean them regularly. Use a cotton swab moistened with cleaning solution (such as alcohol).

Note:

1. Some cleaning cassettes on the market have a strong abrasive effect and scratch the heads. Use cotton swab instead of cleaning cassettes.
2. Since the use of metal tapes is apt to collect more dust on the heads, clean the heads more often to enjoy optimum sound.

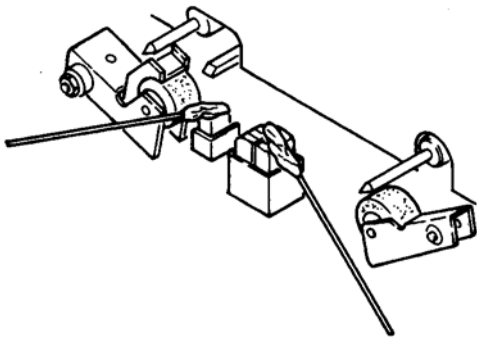

- **Cleaning the Pinchroller and the Capstan**

If the pinchroller or the capstan accumulate dust, tape transport may become unstable resulting from slippage during recording or playback. The tape can also be damaged by being rolled up around the capstan. Clean them with a cotton swab or soft cloth moistened with cleaning solution (such as alcohol).

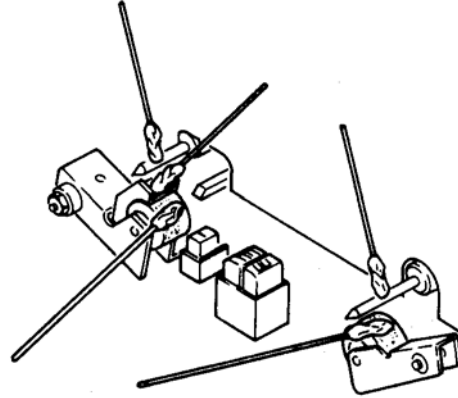

- **Demagnetizing the Heads**

The heads may become magnetized after long usage or by having a strongly magnetized object brought near them. The result is a generation of noise, loss of the high frequency range, or erasing the treble components of pre recorded tapes and adding noise.

Demagnetize the heads on a regular basis.

- **Procedure**

1. Be sure to turn "off" the power supply.
2. Turn the demagnetizer "on" while it is more than 30cm away from the heads. Bring the demagnetizer near the heads and slowly move it in a small circle four or five times.
3. Slowly move the demagnetizer away from the heads and turn "off" the power of the demagnetizer when it is about 30cm away from the heads.

TROUBLESHOOTING

Make sure of the followings before you consider as any malfunctions:

1. Are all the connections correct?
2. Is the set being operated correctly in accordance with the operating instructions?
3. Are the speakers and amplifiers functioning correctly?

If the tape deck still does not function properly, check it again, using the check list below. If the symptom does not correspond to the check list, please contact your DENON dealer.

Problem	Cause	Remedy
Tape does not run.	<ul style="list-style-type: none"> • Power cord is off. • Tape is completely wound up. • Tape is loose. • Cassette is not loaded properly. • Defective cassette. 	<ul style="list-style-type: none"> • Check power cord. • Rewind tape. • Tighten tape with a pencil, etc. • Load cassette properly. • Replace cassette.
Tape is not recorded when recording button is pressed.	<ul style="list-style-type: none"> • No cassette is loaded. • Erase prevention tab is broken off. 	<ul style="list-style-type: none"> • Load cassette. • Cover hole with plastic tape.
Sound is warbled or distorted.	<ul style="list-style-type: none"> • Heads, capstan or pinchroller are contaminated • Tape is wound too tight. • Recording input level is too high. • Tape is worn out and has "drop outs". 	<ul style="list-style-type: none"> • Clean them. • Fast forward or rewind to loosen tape winding. • Adjust recording input level. • Replace tape.
Excessive noise.	<ul style="list-style-type: none"> • Tape is worn. • Heads, capstan or pinchroller are contaminated • Heads are magnetized. • Recording input level is too low. 	<ul style="list-style-type: none"> • Replace tape. • Clean them. • Demagnetize heads. • Adjust recording input level.
High frequency (treble) is emphasized.	<ul style="list-style-type: none"> • Dolby NR button is set improperly. 	<ul style="list-style-type: none"> • Set Dolby NR button properly.
High frequency (treble) is lost.	<ul style="list-style-type: none"> • Heads are contaminated. • Tape is worn. 	<ul style="list-style-type: none"> • Clean them. • Replace tape.
When a Cr02 or metal tape is placed in the deck, a different tape indicator comes on.	<ul style="list-style-type: none"> • The cassette housing is of an older design without tape type detection holes. 	<ul style="list-style-type: none"> • Use the latest cassette with tape type detection holes.
The cassette tape cannot be removed.	<ul style="list-style-type: none"> • If the power switch is turned off in either the recording or playback mode, and the unit is stopped, there may be case when the cassette cannot be removed, even if the EJECT button is pressed. 	<ul style="list-style-type: none"> • Turn the power switch ON again, and then press the stop button. • Then, in the stop mode, press the EJECT button to remove the cassette tape.

SPECIFICATIONS

Type	Vertical tape loading; 4 track 2 channel stereo cassette deck	Outputs:	
Heads	Recording head (amorphous) x 1 Playback head (amorphous) x 1 Erase head (Double gap ferrite) x 1	Line XLR Type Connector	1.23 V (+4 dBm) (with 600 ohms load, recorded level of 200 pwb/ mm)
Motors	Capstan (DC servo motor) x 1 Reel (DC motor) x 1 Actuator (DC motor) x 1	RCA Pin Jack	775 mV (0 dBm) (with 47k ohms load, recorded level of 200 pwb/mm)
Tape Speed	4.8 cm/sec. (FIX)	Headphone	1.2 mW output level at maximum (optimum load impedance 8 ohms ~ 1.2 k ohms)
Variable (PLAY)	Approx. ±12%	Power Supply	Voltage is shown on rating label
Fast Forward,		Power Consumption	22 W
Rewind Time	Approx. 100 sec. with a C 60 cassette	Dimensions	483 (W) x 134 (H) x 275 (D) mm (19" x 5 17/64" x 10 53/64")
Recording Bias	Approx 105 kHz	Weight	5.1 kg (11 Lbs 11 oz)
Overall S/N Ratio (at 3% THD level)	Dolby C NR on: more than 75 dB (CCIR/ARM)	Installation	19 inch rack mountable (3U)
Overall Frequency Response	20 ~ 20,000 Hz ±3 dB (at 20 dB, Metal tape)	<ul style="list-style-type: none"> • Above specifications and design styling are subject to change for improvement. • Dolby noise reduction and HX Pro headroom extension manufactured under license from Dolby Laboratories Licensing Corporation. HX Pro originated by Bang & Olufsen. • "DOLBY", the double D symbol and "HX PRO" are trademarks of Dolby Laboratories Licensing Corporation. 	
Channel Separation	More than 40 dB (at 1 kHz)		
Crosstalk	More than 65 dB (at 1 kHz)		
Wow & Flutter	0.038% WRMS (JIS method), ±0.1 % w. peak		
Inputs			
Line XLR Type Connector	1.23 V (+4 dBm) input level at maximum Input impedance: 200 ohms balanced		
RCA Pin Jack	80 mV (20 dBm) input level at maximum Input impedance: 50 k ohms unbalanced		